

MAGIS

Alpina by Edward Barber & Jay Osgerby



Edward Barber & Jay Osgerby



Profile:

Internationally acclaimed designers Edward Barber and Jay Osgerby founded their eponymous studio in 1996 after graduating with Master's degrees in Architecture from The Royal College of Art in London.

Barber and Osgerby's research-led practice has developed collections for Magis, Vitra, B&B Italia, Venini, Cappellini, Swarovski, Flos and Established & Sons, whilst also producing edition furniture and one-off works for both private and public commissions. Both Honorary Doctors of Arts, Barber and Osgerby have lectured internationally and hosted workshops at Ecal, Switzerland, and the Vitra Design Museum. Their work is held in permanent collections around the world including

the V&A Museum, London; New York's Metropolitan Museum of Art; London's Design Museum; and the Art Institute of Chicago.

Alongside their eponymous studio, in 2001 Barber and Osgerby founded Universal Design Studio, now recognised as one of the world's most innovative creative design consultancies working in architecture, interiors and exhibition design. In 2011 Barber and Osgerby were appointed to design the London 2012 Olympic Torch, while in 2012, the pair followed this with the launch of MAP, a strategy-based industrial design studio that draws on the creative and commercial skills of Barber & Osgerby to provide design intuition, creative direction and research to ambitious clients.



Design and

Alpina, the new chair designed by British designers Edward Barber and Jay Osgerby, defines a new archetype for chairs from a perspective of all-round sustainability. It's inspired by a classical model of the alpine furniture tradition, known for its simple design and multifunctional uses. It's elegant and versatile, capable of adapting to both traditional and more contemporary environments.

Simple and clean, yet curvaceous and enveloping, the new chair combines a solid ash wood frame (FSC certified) with an injection moulded backrest in bio-based polypropylene that derives 100% from waste cooking oils. Fully recyclable.

"As designers we have a great responsibility to adopt a sustainable and circular approach at the core of our working practice. First and foremost we design with longevity in mind...Every piece we launch is intended to be passed down through the generations as a coveted heirloom...The bioplastic utilised in the design of Alpina is a step towards a future where all new designs are created from responsible materials, with both hardwearing and recyclable properties." Edward Barber and Jay Osgerby say.

Alpina is available in three variations: natural ash seat and legs with an olive green backrest, natural ash seat and legs with a beige backrest, black stained ash seat and legs with a black backrest. It's suitable for both domestic and contract use.



Engineering



“The bioplastic utilised in the design of Alpina is a step towards a future where all new designs



are created from responsible materials, with both hardwearing and recyclable properties”



Information



Product

The project of Alpina was born from the desire to create an ecological chair that responds to the principles of the Circular Economy.

The backrest is made of a bio-based polypropylene that derives from organic waste cooking oils. A green and versatile material that represents a good choice for the future of our planet. It has excellent properties, is durable and recyclable, and its production process enables a reduction of the CO2 footprint of up to 40% compared to the manufacturing of traditional plastics.

Seat and legs, in FSC certified solid ash wood, are completely natural. We can say that Alpina is 100% recyclable.





Seat and legs in solid ash / natural
Back in bio-based polypropylene / olive green



Seat and legs in solid ash / natural
Back in bio-based polypropylene / beige



Seat and legs in solid ash / stained black
Back in bio-based polypropylene / black

Seat cushion

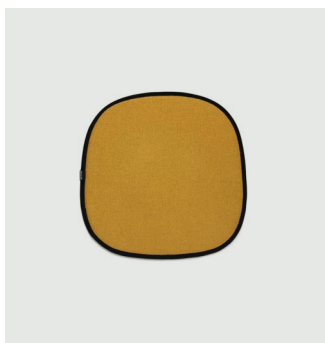

Fabric cat 01
Fabric cat 02

Materials /

Seat and legs in solid ash /

Back in bio-based polypropylene

Fabric cat 1 /

Fabric cat 2 /

Torri Lana Rico

Kvadrat Divina MD
Kvadrat Divina Melange
Kvadrat Divina 3

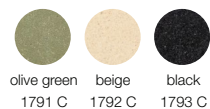
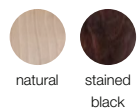

Alpina chair

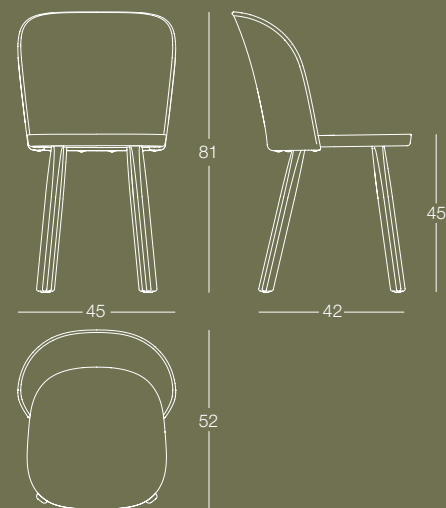

Seat cushion

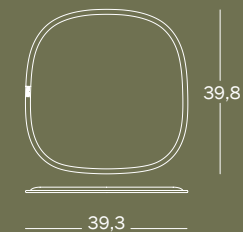

PRODUCT CARE

For the plastic part we recommend using a soft rag, either dry or wet. When needed, use ph-balanced soap diluted in water. For the wooden parts we recommend using a soft, either dry or wet, rag. When needed, use ph-balanced liquid soap especially formulated for wood, diluted in water. Do not use abrasive sponges as they may leave scratches. Avoid using acidic products, solvents and products containing ammonia. Periodic and correct maintenance allows the product to keep its original aspect and lengthens the duration of its performance.

WARNING

Do not use different cleaning products from the ones mentioned above. Do not use the product in an improper way. Do not place hot objects on it, sit on the back, stand on it or use the product as a ladder. Once disused, please make sure that this product is disposed in an environment-friendly way.

Fabrics /

Fabric cat 1 /

Torri Lana Rico



Fabric cat 2 /

Kvadrat Divina MD

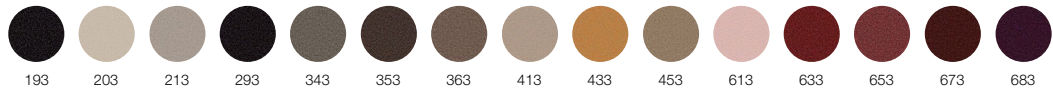

Kvadrat Divina Melange

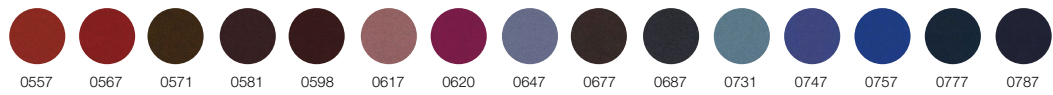
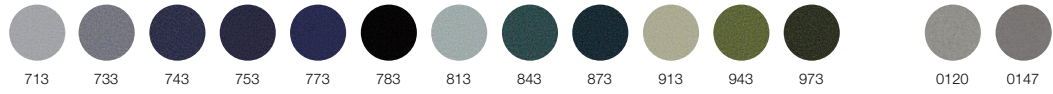

Kvadrat Divina 3

