

MAGIS

Bureaurama by Jerszy Seymour



Jerszy Seymour



Profile:

Jerszy Seymour (CA & UK, born 1968) is a designer, artist and director and cofounder of the Dirty Art Department. He sees design as the general relationship we have with the built world, the natural world, other people and ourselves, and as much about the inhabitation of the planet as the inhabitation of the mind. Spanning from industrially and post-industrially produced objects, actions, interventions and installations, he defines his work as the creation of situations that seek to expand utopian possibilities defined by the idea of the Every-topia and the Non-Gesamt Gesamt Kunstwerk (the non-total total artwork).

His work has been presented in many museums and institutions and is held in many permanent collections including the Centre Georges Pompidou, MAK, Vienna, Kunsthhaus Glarus, the Vitra Design Museum, the Museum of Modern Art, Marta Herford, Mudam Luxembourg,

Fondation Lafayette and the 'Fonds National d' Art Contemporain' France. In parallel he has created objects for design companies such as Magis, Vitra and Kreo and has taught and given lectures and workshops at many schools including the Royal College of Art, UdK, Domus Academy, La Sapienza, Eindhoven Academy, Berlin Program for Artists, Hfg Karlsruhe and Saarbrücken, Cranbrook Academy, Ecal Lausanne and the HEAD in Geneva. In 2011, together with Catherine Geel, Stephane Barbier Bouvet, and Clemence Seilles, he cofounded the Dirty Art Department, a radical masters program in art and design at the Sandberg Institute in Amsterdam.

In 2021, he created the exhibition 'Life on Planet Orsimanirana' at the Museum für Kunst und Gewerbe Hamburg, together with the Macao Collective in Milan, as an active process of world building and a symbolic vision of a world we would want to live in.



Design and

Bureaurama combines a simple aesthetic with a lightweight structure. All products are made from fully recyclable, welded aluminium and available in a black splattered white finish or in four vibrant colours. The bookshelf's uprights are made of steel tube painted in polyester powder, the shelves are made of steel plate painted. The tables and stools are fire-resistant and suitable for outdoor use.

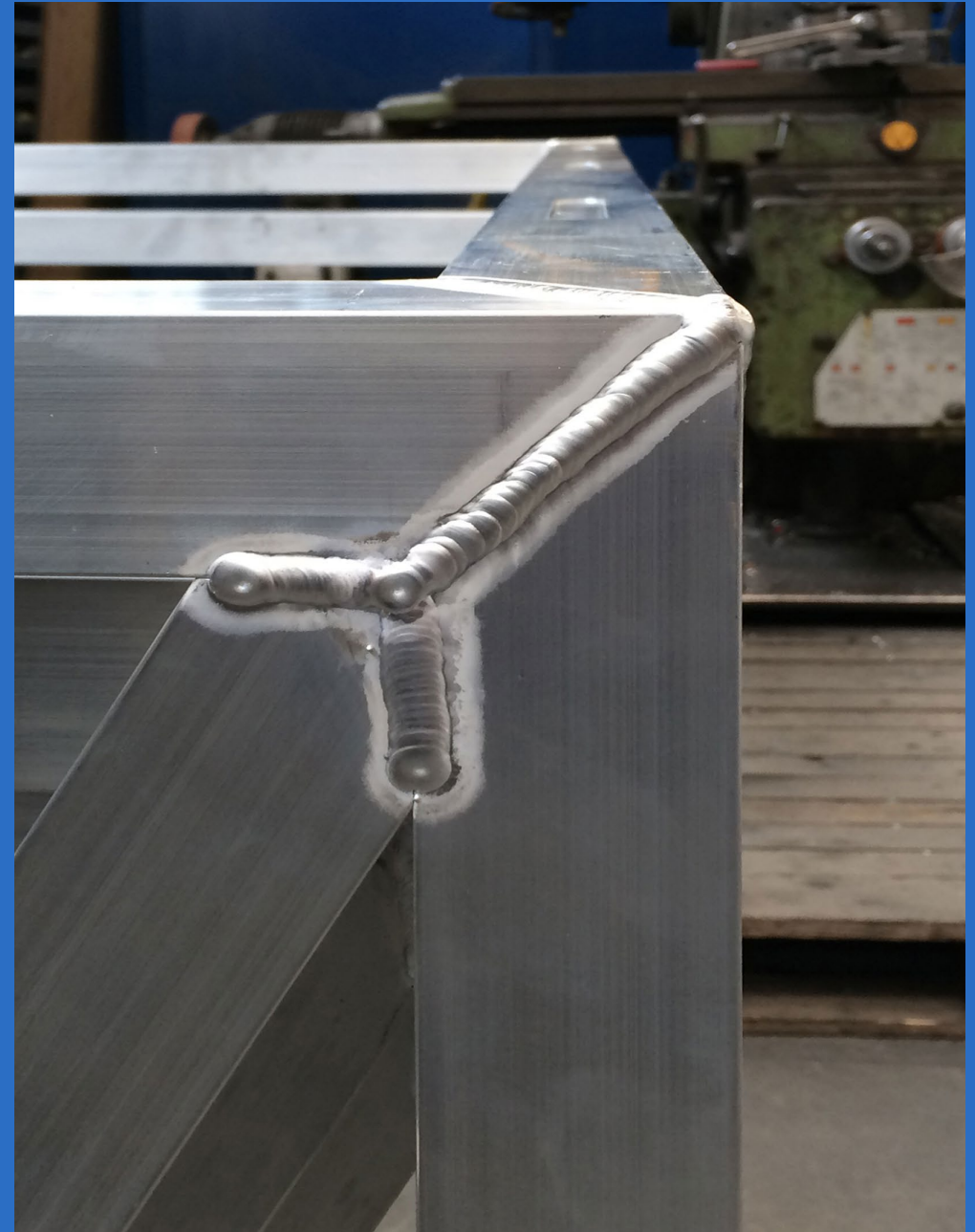

Engineering



“ The material is lightweight recyclable aluminium



which is bent by high welding technology ”



Information



Product

Bureaurama is a collection of tables and stools. It is conceived for a dynamic and constantly evolving workplace and is a new way of seeing the office as a space that is functional and shared, yet freely customisable.

The graphics and the essential lines of the collection break the schemes of monotony, bringing a breath of lightness to the workplace and making it possible to configure even smarter solutions for work or socialisation, becoming a hub for exchanging new ideas and new visions.



HIGH BAR STOOL



Black
(splattered white)



Fluorescent orange
5266



Yellow 5268



Blue 5267



Grey 5119

MEDIUM BAR STOOL



Black
(splattered white)



Fluorescent orange
5266



Yellow 5268



Blue 5267



Grey 5119

LOW BAR STOOL



Black
(splattered white)



Fluorescent orange
5266



Yellow 5268



Blue 5267



Grey 5119

TABLES



Black
(splattered white)



PRODUCT CARE

We recommend using a soft rag, either dry or wet. When needed, use ph-balanced soap diluted in water. Do not use abrasive sponges as they may leave scratches. Avoid using acidic products, solvents and products containing ammonia. Periodic maintenance and cleaning allows the products to keep their original look and lengthens the duration of their performance.

WARNING

Do not use different cleaning products from the ones mentioned above. Do not use the product in an improper way. Do not place hot objects on it, stand on it or use the stool as a ladder. Once disused, please make sure this product is disposed in an environment-friendly way.

Stools

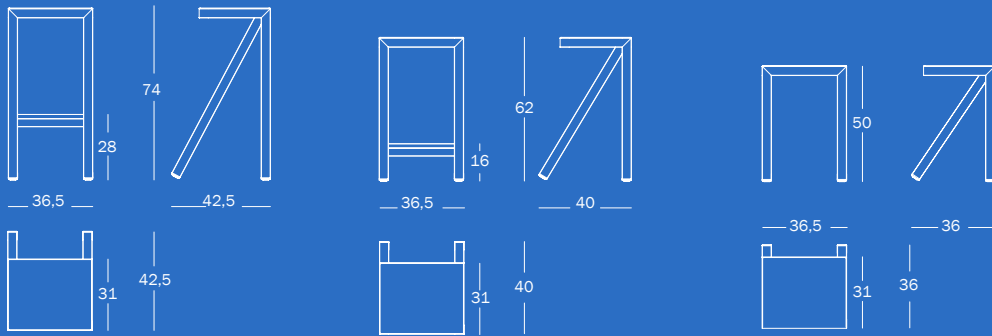

Examples of composition for tables with height of 102,5 cm

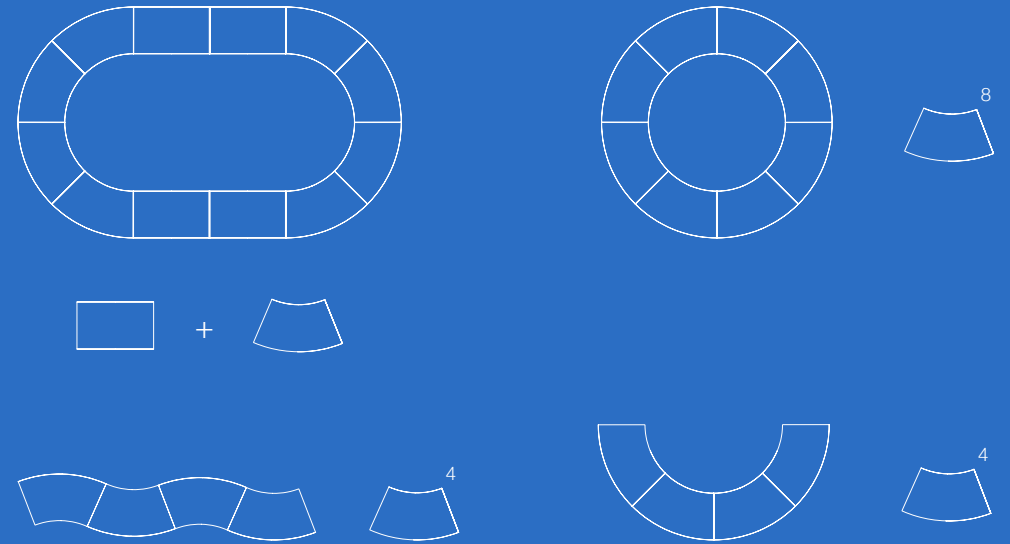

Tables

