

MAGIS

Traffic by Konstantin Grcic



Konstantin Grcic



Profile:

Konstantin Grcic (*1965) was trained as a cabinet maker at The John Makepeace School for Craftsmen in Wood before studying Design at the Royal College of Art in London. Today Konstantin Grcic Design is based in Berlin and active in several fields ranging from industrial design projects, exhibition design and collaborations in architecture and fashion.

Among his producers, besides Magis, are Artek, Authentics, Cassina, ClassiCon, Flos, Flötto, Kettal, Laufen, Mattiazzi, Muji, Mutina, Nespresso, Plank, Serafino Zani and Vitra. From the fashion and lifestyle sector, Audi, Hugo Boss, Issey Miyake, Louis Vuitton, Prada,

Rado and smart/Daimler are some of his clients. Many of his products have been awarded international design prizes. He received the Compasso d'Oro in 2001 for the Mayday lamp (Flos), 2011 for the Myto chair (Plank) and 2016 for the OK lamp (Flos). For Tom and Jerry from Magis' series The Wild Bunch he received the German Design Award in Gold in 2011.

Grcic defines function in human terms, combining formal strictness with considerable mental acuity and humour. His work is characterised by a careful research into the history of art, design and architecture and his passion for technology and materials.



Design and

Soft, geometrical volumes, with fabric or leather covering, supported on slender, metallised painted metal rod frames: this is the starting point from which Traffic developed. This complete collection of upholstery combines simplicity with refinement, and uses colour as a multifarious and expressive language.

Playing on different proportions, the basic concept of Traffic is elaborated in a number of different forms: an armchair, a two-seater and three-seater sofa, a bench, an ottoman, a chaise longue and an island. The collection has expanded further to include two low tables, one large, one small, and a high table, again with a metal rod frame, but with a top in artificial stone, adding another tactile sensation to the home and contract scenario.



Engineering

Information



Product

ARMCHAIR / SOFA / CHAISE LONGUE

Frame in steel rod, painted in polyester powder. Cushions in expanded polyurethane, fireproof (class 1IM) covered in leather or with removable cover in fabric. Complete with felt pads. Acrylic stone tablet available.

OTTOMAN / BENCH

Frame in steel rod, painted in polyester powder. Cushions in expanded polyurethane, fireproof (class 1IM) with removable cover in Fabric or in leather.

PLATFORM

Frame in steel rod, painted in polyester powder. Cushions in expanded polyurethane, fireproof (class 1IM) covered in leather or with removable cover in fabric. Tablet in acrylic stone available. Complete with felt pads.

LOW TABLE

Frame in steel rod painted in polyester powder. Top in acrylic stone with dressed surface or in veneered oak natural or painted black.

ARMCHAIR



Frame in steel /	Upholstery /
Colours	Fabric cat 1
Colours	Fabric cat 2
Colours	Fabric cat 3
Colours	Leather

SOFA



Frame in steel /	Upholstery /
Colours	Fabric cat 1
Colours	Fabric cat 2
Colours	Fabric cat 3
Colours	Leather

CHAISE LONGUE



Frame in steel /	Upholstery /
Colours	Fabric cat 1
Colours	Fabric cat 2
Colours	Fabric cat 3
Colours	Leather

Materials /

Frame in steel /

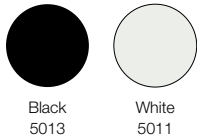

Fabric cat 1 /	Fabric cat 2 /	Fabric cat 3 /	Leather /
Glamour Azimut	Kvadrat Tonus Kvadrat Colline Kvadrat Tonica	Kvadrat Coda	Boxland 7260 / brown Boxland 71650 / black

Armchair

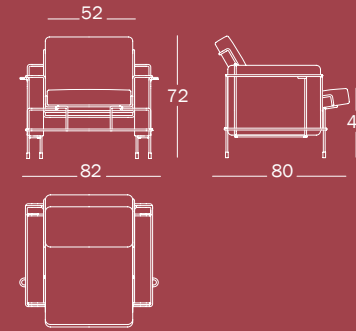

Sofa 2 seaters

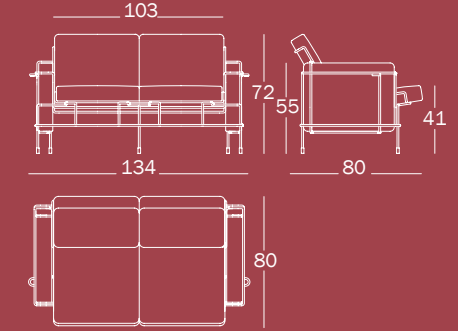

Sofa 3 seaters

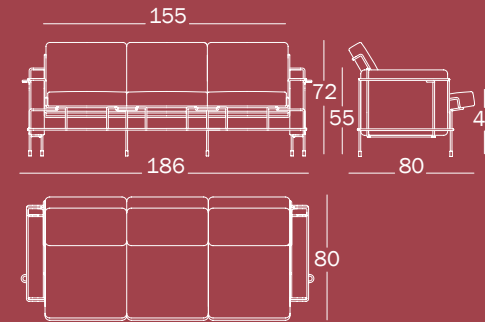

Chaise Longue

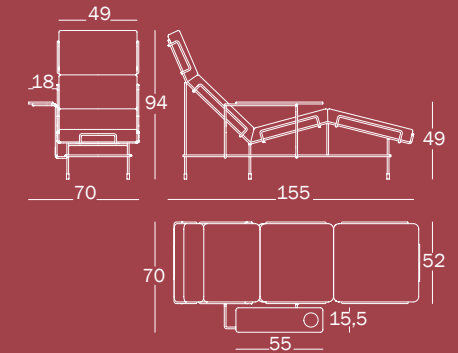



OTTOMAN



Frame in steel /
Colours
Colours
Colours
Colours

Upholstery /
Fabric cat 1
Fabric cat 2
Fabric cat 3
Leather

BENCH



Frame in steel /
Colours
Colours
Colours
Colours

Upholstery /
Fabric cat 1
Fabric cat 2
Fabric cat 3
Leather

PLATFORM



Frame in steel /
Colours
Colours
Colours
Colours

Upholstery /
Fabric cat 1
Fabric cat 2
Fabric cat 3
Leather

Materials /

Frame in steel /

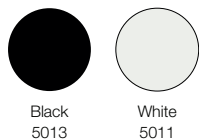

Fabric cat 1 / Glamour Azimut	Fabric cat 2 / Kvadrat Tonus Kvadrat Colline Kvadrat Tonica	Fabric cat 3 / Kvadrat Coda	Leather / Boxland 7260 / brown Boxland 71650 / black
----------------------------------	--	--------------------------------	--

Ottoman

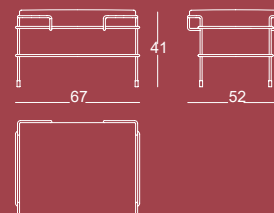

Bench

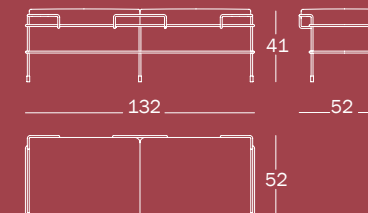

Platform

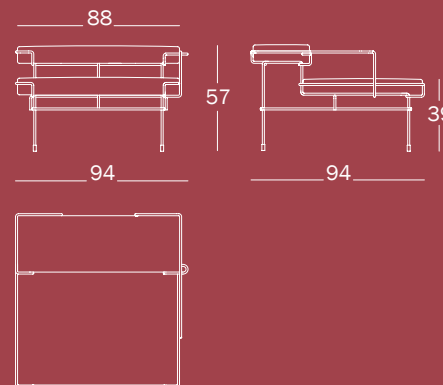

Fabric cat 1 /

Glamour Azimut



Fabric cat 2 /

Kvadrat Tonus

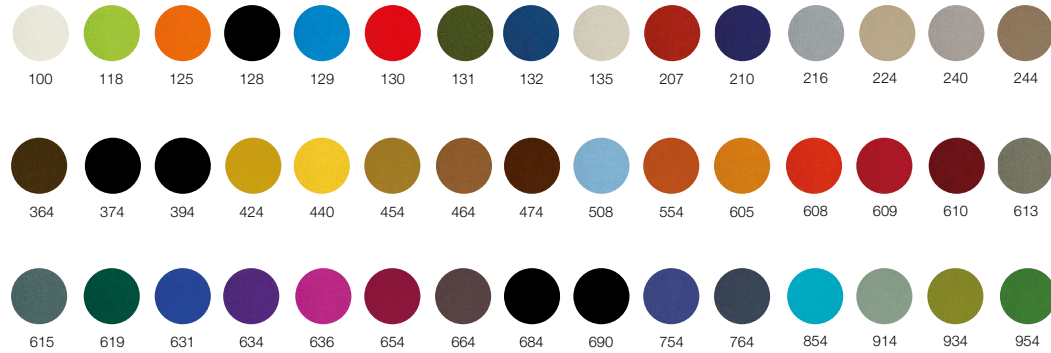

Kvadrat Colline



Kvadrat Tonica

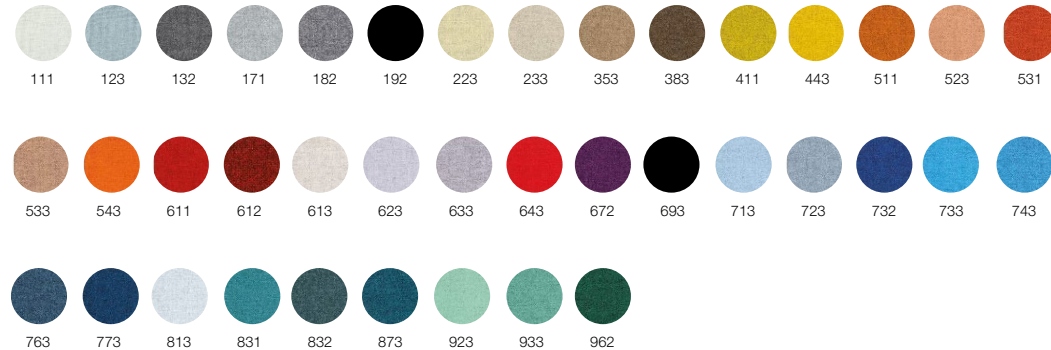

Fabric cat 3 /

Kvadrat Coda

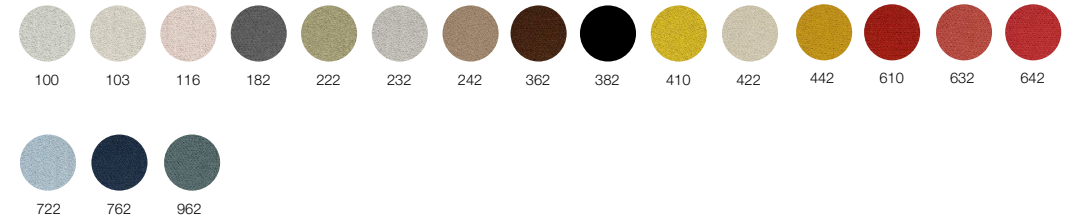

Leather /

Boxland

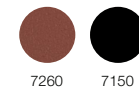

PRODUCT CARE

FABRIC

Regular cleaning is important in order to keep the upholstery textile looking its best and to prolong its life. Dust and dirt wear down the textile and also reduce its re-retardant properties. Vacuum frequently, ideally every week. Use the vacuum at half power when appropriate. We recommend that upholstered furniture in commercial environments are cleaned by professionals 2 to 3 times a year. Treat stains immediately, the longer they remain in the fabric, the harder it is to remove them. Before choosing a cleaning method, always try it out on a concealed part of the product. First, scrape off any liquids or hardened residues. Next, vacuum before further cleaning. Non-greasy stains can be removed by gently dabbing with a moist sponge or lint-free cloth. Work in circular motion towards the centre of the stain. Always ensure the textile is fully dry before using the furniture again.

Using a hairdryer can help to avoid edge marks, particularly with microbre fabrics. Please note: these tips are purely recommendations and do not guarantee complete stain removal. In all cases, we recommend contacting a professional dry cleaner. Be careful when using solvents, because these could dissolve the upholstery material beneath. Removable covers made from wool cannot be washed but should be dry cleaned. We do not recommend impregnation of woollen upholstery fabrics, as wool itself is dirt-repellent. In order to ensure satisfying cleaning results, we recommend to contact a professional cleaning institute. Employing pH-neutral carbon dioxide solutions for cleaning is recommended because this method avoids the use of soap. A professional cleaning institute may also assist in working out maintenance schedules, which ensure that the fabrics are maintained properly so that a good indoor climate and a maximum duration of the upholsteries are achieved.

LEATHER

Regularly clean using a dry and soft rag. When needed, use products especially formulated for leather. Immediately dry after the treatment. Do not use abrasive sponges as they may leave scratches. Where there was a stain of ink or similar, use only the specific stick that is commonly available on the market. Avoid direct exposure to sunlight or heat sources. For untreated premium-grain leather, please treat eventual stains immediately using only a damp cloth. Avoid any kind of chemical detergents.

WARNING

In order to ensure that its removable upholstery can be perfectly replaced, the assistance of a specialized upholsterer is required. Do not use different cleaning products from the ones mentioned above. Do not use the product in an improper way. Do not place hot objects on it, sit on the back, stand on it or use the product as a ladder. Once disused, please make sure this product is disposed in an environment-friendly way.



LOW TABLES



Frame in steel /	Top /
white	white acrylic stone
black	grey anthracite acrylic stone
white	veneered oak natural
black	veneered oak black

Materials /

Frame in steel /

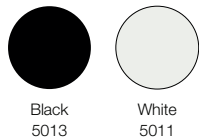

Black
5013

White
5011

Top in acrylic stone /



grey
anthracite

white

Top in veneered oak /

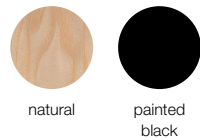

natural

painted
black

Low table 45x30

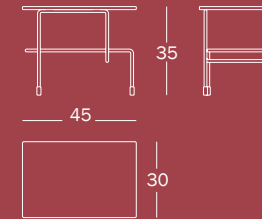

Low table 60x60

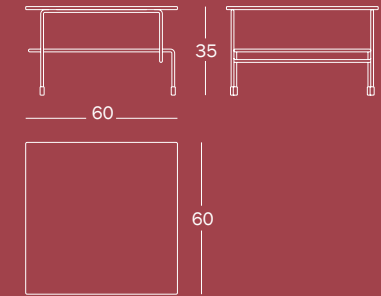

Low table 81x26

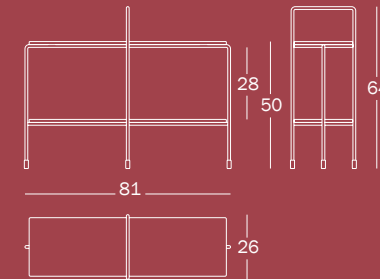

PRODUCT CARE

Tops in acrylic stone are in a durable and hard-wearing material, easy to clean. We recommend using a soft rag, either dry or wet. When needed, use ph-balanced soap diluted in water. Tougher stains can easily be removed using a bleaching or a scouring agent. Afterwards clean the surface with a domestic all-purpose cleaner and rinse with clean water. Avoid using cleaning agents containing acids, such as methyl chloride or acetone. Periodic and correct maintenance allows the product to keep its original aspect and lengthens the duration of its performance.

WARNING

Do not use different cleaning products from the ones mentioned above. Do not use the product in an improper way. Do not place hot objects on it, sit or stand on it, use it as a ladder. Once disused, please make sure that this product is disposed in an environment-friendly way.



