

Traffic_2

Design Konstantin Grcic, 2013

Chaise longue.

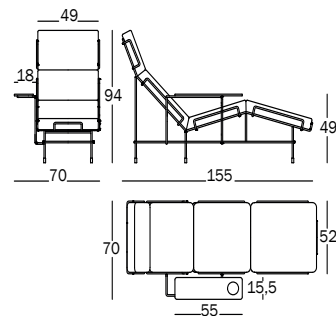

Frame in steel rod, painted in polyester powder. Cushions in expanded polyurethane, fireproof (class 1IM) covered in leather or with removable cover in fabric.

Supplied with tablet in acrylic stone with dressed surface. Complete with felt pads.



9401.71.00 | 0,934 m³ | 37,40 kg

Art. nr.	Frame in steel	Upholstery
SD1160	colours	fabric cat.1
SD1161	colours	fabric cat.2
SD1162	colours	fabric cat.3
SD1164	colours	leather

Frame in steel	Fabric cat.1	Fabric cat.2	Fabric cat.3	Leather
 white 5011	Glamour Azimut	Kvadrat Tonus	Kvadrat Coda	Boxland 7260/ brown
 black 5013		Kvadrat Colline		Boxland 7150 / black
		Kvadrat Tonica		

Test

ANSI-BIFMA X5.4-2012
 Arm fatigue test EN 16139:2013, L2
 Arm sideways static load test EN 1728:2012
 Back impact test EN 16139:2013, L2
 Leg sideways static load test EN 16139:2013, L2
 Seat and back static load test EN 1728:2012
 Seat impact test EN 16139:2013, L2
 Vertical load on back rest EN 1728:2012

Arm downwards static load test EN1728:2012
 Arm rest impact test EN 16139:2013, L2
 Auxiliary writing surface durability test EN 1728:2012
 Leg forward static load test EN 16139:2013, L2
 Seat and back fatigue test EN 1728:2012
 Seat front edge durability test EN 1728:2012
 Stability EN 1022:2005
 Vertical static load on auxiliary writing surfaces EN 1728:2012



Information on customer's own material from p.397

