

Tambour

Design Ronan & Erwan Bouroullec, 2012

Low table H.36 cm.

Frame in polished die-cast aluminium. Top in polished aluminium.

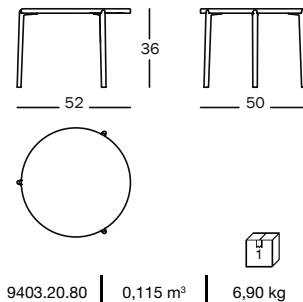

9403.20.80 | 0,115 m³ | 6,90 kg

Art. nr.	Frame	Top
TV1100	polished die-cast aluminium	polished aluminium

Table H.65 cm.

Frame in polished die-cast aluminium. Top in polished aluminium.

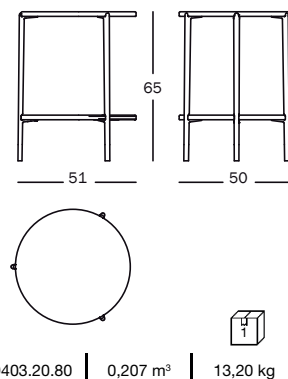

9403.20.80 | 0,207 m³ | 13,20 kg

Art. nr.	Frame	Top
TV1105	polished die-cast aluminium	polished aluminium

Table on wheels H.65 cm.

Frame in polished die-cast aluminium. Top in polished aluminium.

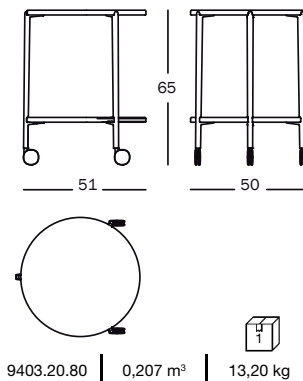

9403.20.80 | 0,207 m³ | 13,20 kg

Art. nr.	Frame	Top
TV1110	polished die-cast aluminium	polished aluminium

Frame + Top

Top thickness



polished aluminium

aluminium: 20 mm



As die-cast aluminium is not treated with any chemical products or any kind of painting, small marks or irregularities, which might be visible on the surface, should not be considered as faults, but on the contrary as technical results of the nature of aluminium itself. We recommend using specific cleaning products for aluminium. Aluminium is very likely to dull while using. Regular care is therefore necessary to maintain its original appearance.