

MAGIS

Air-Family by Jasper Morrison



Jasper Morrison



Profile:

Jasper Morrison was born in London in 1959. He graduated in Design at Kingston Polytechnic Design School, London and The Royal College of Art for Postgraduate studies which included a scholarship at HdK in Berlin. In 1986 he set up an Office for Design in London. Today Jasper Morrison Ltd. consists of three design offices, a main office in London and two branch offices: one in Paris (opened 2002) and one in Tokyo (opened 2007). Services offered by Jasper Morrison Ltd. are wide ranging, from tableware and kitchen products to furniture and

lighting, sanitary-ware, electronics and appliance design.

He has clients across the globe, all leaders in their individual fields. The collaboration with Magis started in the 90s and became a long lasting and fruitful relationship. Today our range includes products such as the stackable Bottle rack, the legendary Air-Family made in gas-injection moulding, the streamlined paper bin Trash or the Pipe collection made of tubular aluminium frames. Among these Plato is the latest member and a further proof for a successful relationship.

Design and

Air-Family takes its name from the “air-moulding” technology that makes it possible to create highly resistant yet super-lightweight products out of polypropylene added with fibreglass.

Harmonious, dynamic, stackable, and suitable for indoor or outdoor use, table and chairs create a welcoming atmosphere anywhere: at home or in a collective space, in the kitchen, the dining room or the garden.

The products are available in a range of colours to suit any taste and style.

The chairs come with or without armrests and are also available as foldable version.



Engineering



“ The hollow core achieved through the use of air-moulding tech-



nology makes Air-Chair the epitome of the reductive design ”

Murray Moss



Information



Product

Less is more - that's Jasper Morrison's claim when it comes to design. The Air-Family impresses with its simple design in both form and function. Table and chairs are made of polypropylene and manufactured using gas-injection moulding.

All the products of the family are strong, durable, lightweight and perfect for domestic use and contracts (bars and restaurants). Practical and easy to clean you'll be able to storage them in small space and to use when you need.



AIR-CHAIR



White 1730 C



Beige 1450 C



Orange 1086 C



Black 1751 C

AIR-ARMCHAIR



White 1730 C



Beige 1450 C



Orange 1086 C



Grey anthracite 1418 C

FOLDING AIR-CHAIR

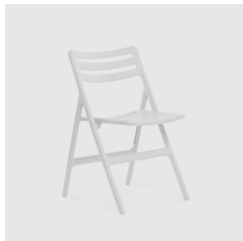

White 1730 C

AIR-TABLE



White 1730 C

LINKING DEVICE



PVC transparent neutral

WALL HOOK



Chromed steel rod

Air-Chair

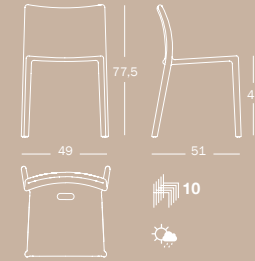

Air-Armchair

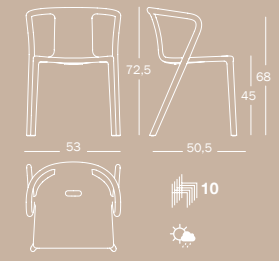

Folding Air-Chair

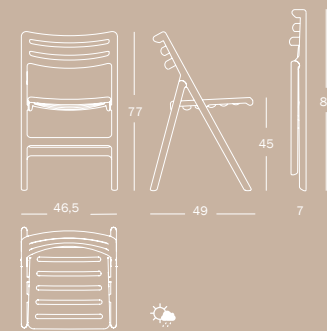

Air-Table

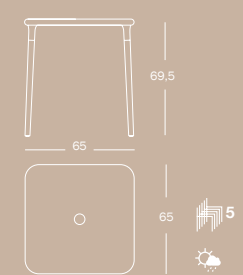

PRODUCT CARE

We recommend using a soft rag, either dry or wet. When needed, use ph-balanced soap diluted in water. Do not use abrasive sponges as they may leave scratches. Avoid using acidic products, solvents and products containing ammonia. Periodic and correct maintenance and cleaning allows the product to keep its original look and lengthens the duration of its performance.

WARNING

Do not use different cleaning products from the ones mentioned above. Do not use the product in an improper way. Do not place hot objects on it, sit on the back and/or on the arms, stand on it or use the product as a ladder. Once dis-used, please make sure that this product is disposed in an environment-friendly way.



